



**PRODUCT APPROVAL OF PACKAGING
FOR TRANSPORTATION OF DANGEROUS GOODS
CERTIFICATE NO.: NET0108A**

HOLDER OF CERTIFICATE:
Emballator Mellerud Plast AB

MANUFACTURER: Emballator Mellerud Plast AB, Box 83, SE-464 22 Mellerud, SWEDEN

MARKING ON PACKAGING:  **3H1/Y1.4/100/YR/N/NET0108A - ID**
"YR" to be replaced with the two last digits of the year.
"ID" to be replaced by any identification as decided by the manufacturer.
The packaging shall also be appropriately marked with the month of the manufacture.

PRODUCT:

Packaging code	Description	Drawings	Material
3H1, plastics jerricans	non-removable head	H0517-410-300 20060404	HDPE, details in report
3H1, plastics jerricans	non-removable head	H0415-410-300 19961115	HDPE, details in report

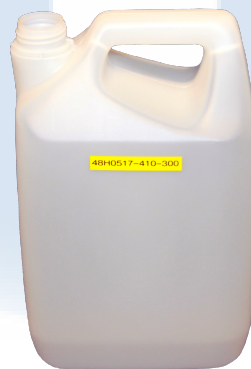

DIMENSIONS:

Weight of jerrycan, g	Volume, litre	Length, mm	Width, mm	Height, mm	Neck size, mm
171.2 - 182	5.0	190	130	296	40
151.1 - 160	4.0	190	130	255	40

CLOSING MECHANISM:

Screw cap	Producer	Drawings	Material	Gasket	Torque, Nm
Child resistant, 40 mm	Emballator Växjöplast AB	12474	HDPE / HDPE	None	7
Child resistant, 40 mm	Emballator Växjöplast AB	12436	HDPE / HDPE	EPE/PET	7
Child resistant, 40 mm	Emballator Växjöplast AB	12436	HDPE / HDPE	EPE/ALU/PET	7
40 mm	Emballator Växjöplast AB	12486	HDPE	Cone	7
40 mm	Modulpac AB	40PMPP/ 7400010	HDPE, details in report	PET/EPE/PET	7
40 mm	Modulpac AB	40PM/ 8400013	HDPE, details in report	Cone	7
Child resistant, 40 mm	Modulpac AB	40B/ 8400002	HDPE, details in report/ HDPE	PET/EPE/PET	7

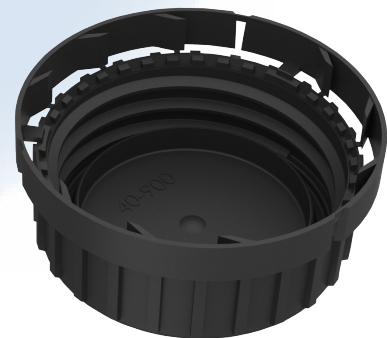
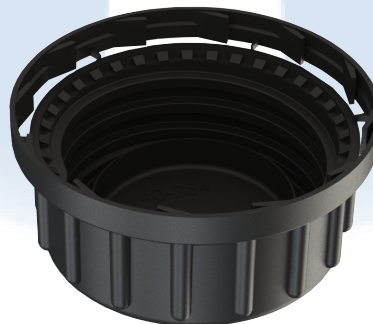
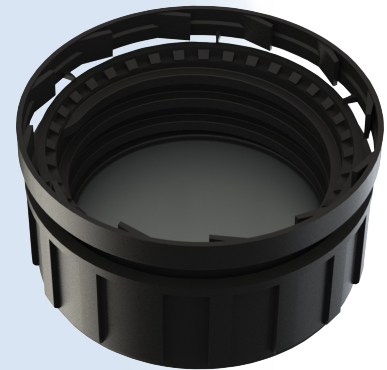
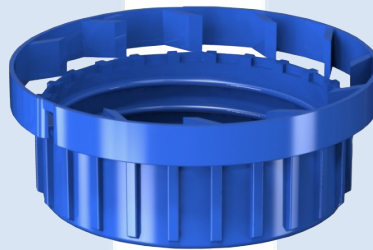
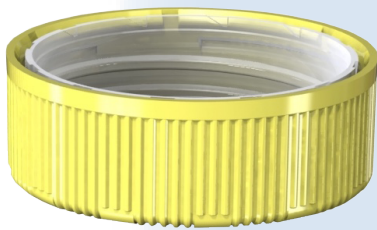

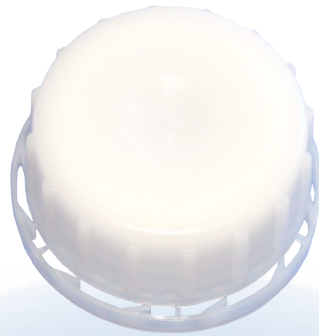

APPROVAL:

The certificate is valid for a maximum of five years, provided no modifications have been made to the packaging design, materials, dimensions, closure system or manner of construction. To ensure validation of the certificate, check the NET website.

NET issues the certification on described product according to delegated authority from Norwegian Directorate for Civil Protection and Emergency Planning (DSB): Legal regulations for Transportation of Dangerous Goods on road and railway - 06/6950-7/BJRU.

NET issues the certification on described product according to delegated authority from Norwegian Maritime Directorate (Sjøfartsdirektoratet) - 200705977-4/5367.1.

NET issues the certification on described product according to an agreement between Norwegian Civil Aviation Authority (Luftfartstilsynet) - 01.03.18 - 18/00114-8.

REGULATIONS BASED UPON FOR APPROVAL:

ADR, European Agreement concerning the International Carriage of Dangerous Goods by Road.

RID, International Regulations on Transport of Dangerous Goods by Rail.

UN Recommendations on the Transport of Dangerous Goods.

IMDG, International Maritime Dangerous Goods Code, for sea transport.

ICAO Technical Instructions for the Safe Transport of Dangerous Goods by Air.

IATA Dangerous Goods Regulations, for the air transport.

APPROVAL IS VALID FOR:

The packaging is valid for packaging group II and III containing liquid substances that are listed in the following table.

The liquids marked with letter A - F are referring to standard liquids listed in ADR 6.1.6.1 and verified by chemical compatibility testing to this specific liquid.

The dangerous substances allowed to transport in the packaging after chemical compatibility with these liquids, are listed in the "Assimilation list" table 4.1.1.21.6 in ADR.

Permeability test has been carried out and approved according to ADR 6.1.5.7.

The packaging shall always be used according to the requirements of the applicable UN-code and its packaging instructions.

Content	Max. relative density	Max. vapour pressure, kPa at +50°C
Standard liquid B: Acetic Acid	1.1	114
Standard liquid C: n-Butyl acetate	1.0	114
Standard liquid D: Mixture of hydrocarbons	1.0	114
Standard liquid F: Water	1.4	114

DOCUMENTS BASED UPON FOR APPROVAL:

Report id.	Date	Issued by	Scope
NET0108A	30.11.2007	NET	Type approval
NET0108A-WL	04.12.2007	NET	Type approval
NET0108A-AA	03.09.2008	NET	Type approval
NET2814A	08.01.2021	NET	Additional test, 40B
NET2814A	03.02.2021	NET	Additional test, 40PM

TEST STANDARD:

All tests are performed in accordance with NET accredited test method ATM001. The test method is accredited in accordance with ISO17025 approved by Norsk Akkreditering and based upon ISO16495 and ISO13274.

The packagings shall be manufactured, reconditioned and tested under a quality assurance programme which satisfies NET Certification, in order to ensure that each packaging meets the requirements in ADR and the guidelines in ISO 16106.



BREVIK, NORWAY

12.01.2021 CERTIFICATE IS VALID UNTIL:

31.01.2026



Geir Morten Johansen
Certification Officer



Rune Madsen Fink
Control Officer

Nordisk Emballasje Testing AS Certification