

**TYPE APPROVAL OF PACKAGING FOR  
TRANSPORTATION OF DANGEROUS GOODS  
CERTIFICATE NO.: NET6741A**

HOLDER OF CERTIFICATE:  
**Emballator Ulricehamns Bleck AB**

**MANUFACTURER:** Emballator Ulricehamns Bleck AB, Maskinvägen 10, SE-52338 Ulricehamn, Sweden

**MARKING ON PACKAGING:**

Each packaging intended for use according to the ADR shall bear markings which are durable, legible and placed in a location as to be readily visible. Letters, numerals and symbols shall be at least 6 mm high.

 **1A1/X1.2 Y1.8 Z2.7/250/YR/N/NET6741A - ID**

-  : The United Nations symbol
- 1A1 : Steel drum, non-removable head
- X1.2 Y1.8 Z2.7 : Packaging group I, II and III, and max and relative density of the substance
- 250 : Hydraulic test pressure in kPa
- YR : To be replaced with the year (last two digits) of manufacture
- N : Norway, the state authorizing the allocation of the mark
- NET6741A - ID : Identification of the packaging followed by "ID" to be replaced by the name of the manufacturer

**PRODUCT:**

Description	Method of manufacture	Material	Drawing
Steel drums, non-removable head	Seamed	Steel sheet	100447



**DIMENSIONS:**

Volume, l	H*Ø, mm	Head/ Body/ Bottom, mm
1: 1.0	230*79	0.30 / 0.20 / 0.20
2: 1.0	224*79	0.30 / 0.20 / 0.20
3: 0.75	168*79	0.30 / 0.20 / 0.20
4: 0.5	122*79	0.30 / 0.20 / 0.20

**CLOSING MECHANISM:**

#: Closure type	Producer	Drawings	Material	Gasket
1: Clamped on lid	Emballator Ulricehamn Bleck AB	100455	Steel sheet TS275	PVC
2: Clamped on lid, S2 center	Emballator Ulricehamn Bleck AB	100458	Steel sheet TS275	PVC
3: Clamped on lid, HZB of center	Emballator Ulricehamn Bleck AB	100459	Steel sheet TS275	PVC
4: Clamped on lid, S2 out of center	Emballator Ulricehamn Bleck AB	100460	Steel sheet TS275	PVC
5: Clamped on lid, HZB out of center	Emballator Ulricehamn Bleck AB	100461	Steel sheet TS275	PVC
6: Clamped on lid	Emballator Ulricehamn Bleck AB	100462	Steel sheet TS275	PU
7: Clamped on lid, S2 center	Emballator Ulricehamn Bleck AB	100463	Steel sheet TS275	PU
8: Clamped on lid, HZB center	Emballator Ulricehamn Bleck AB	100464	Steel sheet TS275	PU
9: Clamped on lid, S2 out of center	Emballator Ulricehamn Bleck AB	100465	Steel sheet TS275	PU
10: Clamped on lid, HZB out of center	Emballator Ulricehamn Bleck AB	100466	Steel sheet TS275	PU

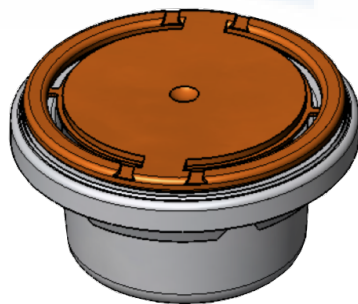

**LEGISLATION:**

NET issues the certification on described product according to delegated authority from Norwegian NET issues the certification on described product according to delegated authority from Norwegian Directorate for Civil Protection and Emergency Planning (DSB): Legal regulations for Transportation of Dangerous Goods on road and railway - 06/6950-7/BJRU.

NET issues the certification on described product according to delegated authority from Norwegian Maritime Directorate (Sjøfartsdirektoratet) - 200705977-4/5367.1.

NET issues the certification on described product according to an agreement between Norwegian Civil Aviation Authority (Luftfartstilsynet) - 01.03.18 - 18/00114-8.

**REGULATIONS BASED UPON FOR APPROVAL:**

UN Recommendations on the Transport of Dangerous Goods.

ADR, European Agreement concerning the International Carriage of Dangerous Goods by Road.

RID, International Regulations on Transport of Dangerous Goods by Rail.

IMDG, International Maritime Dangerous Goods Code, for sea transport.

ICAO, Technical Instructions for the Safe Transport of Dangerous Goods by Air.

IATA, Dangerous Goods Regulations, for the air transport.

**TESTS CARRIED OUT:**

Prototype tests performed and approved according to the above regulations:

6.1.5.3 Drop test

6.1.5.6 Stacking test

**APPROVAL IS VALID FOR:**

The packaging shall always be used according to the requirement of the applicable UN-code and its packaging instruction.

Content	Max. vapour pressure, kPa at +50°C
Liquid substances that do not adversely affect the packaging materials	200
Liquid substances that do not adversely affect the packaging materials	200
Liquid substances that do not adversely affect the packaging materials	200

**DOCUMENTS BASED UPON FOR APPROVAL:**

Report id.	Date	Issued by	Scope
95H12530	18.09.95	SP	Type approval
98H60736	02.12.98	SP	Additional type test, technical evaluation
P404432	21.12.04	SP	Technical evaluation
PX15958A	15.09.11	SP	Additional type Approval

**VALIDITY:**

The continued validity of the type approval requires that the holder of the certificate and/ or the manufacturer inform NET certification that has approved its type of packaging of any changes to the characteristics of the type or anything that can influence on the transport safety on the specific design so that it can be verified that the type of packaging continues to comply with packaging tested as base for the original type approval.

The validity of the type approval assume regular verification by means of periodic audits by NET in accordance with NET Doc 2: "Production control agreement". The packaging shall be manufactured, reconditioned and tested under a quality assurance program which satisfies NET Certification, in order to ensure that each packaging meets the requirements in ADR and the guidelines in ISO 16106.

**TEST STANDARD:**

All tests are performed in accordance with NET accredited test method ATM001. The test method is accredited in accordance with ISO17025 approved by Norsk Akkreditering and based upon ISO16495.



BREVIK, NORWAY

**23.01.2020** CERTIFICATE IS VALID UNTIL:**31.01.2025**

Mathias Werner  
Certification Officer



Rune Madsen Fink  
Control Officer

*Nordisk Emballasje Testing Certification*